

		291.4864 S	
		291.4012 V	291.4012
1GME	16.1.79	Gr	A
			03.79
			Li
			25553
			12.79
			Wk
Rechnerplatte Computer board			Z

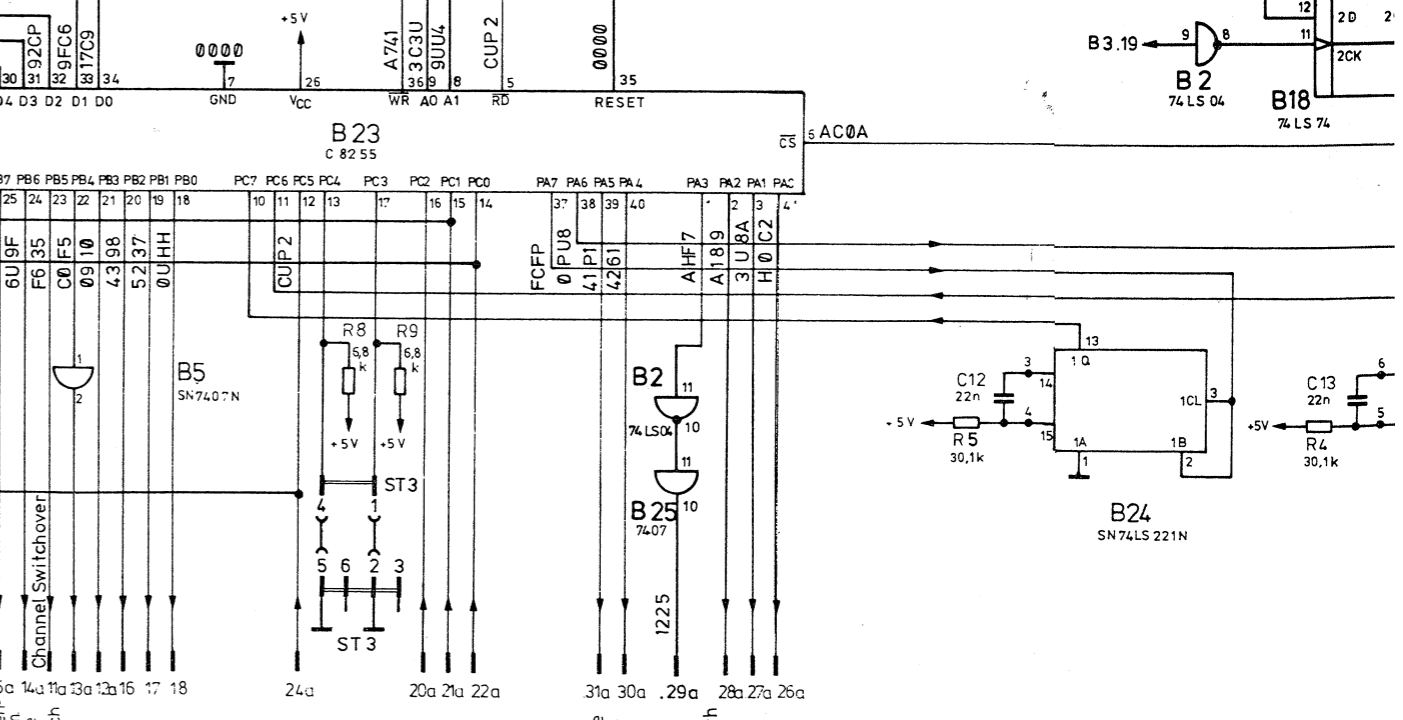

Ansicht und Leitungsführung Bauteilseite
View of tracks on component side

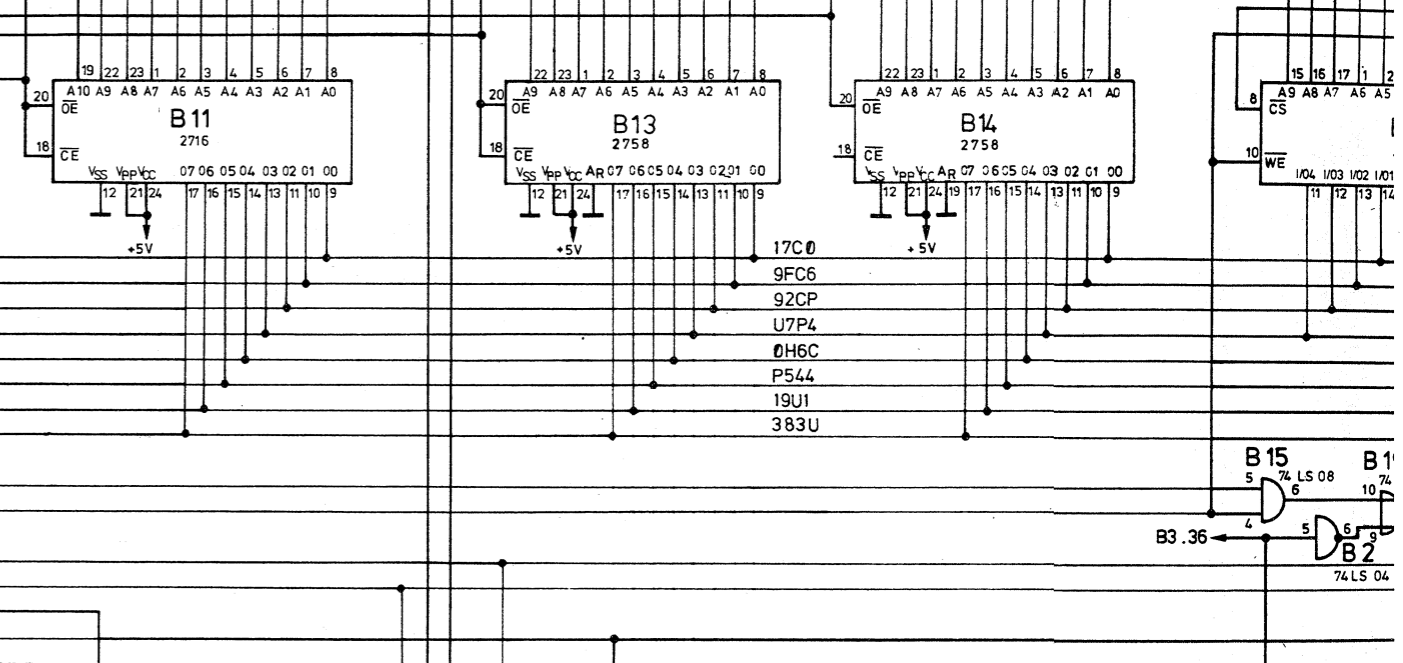
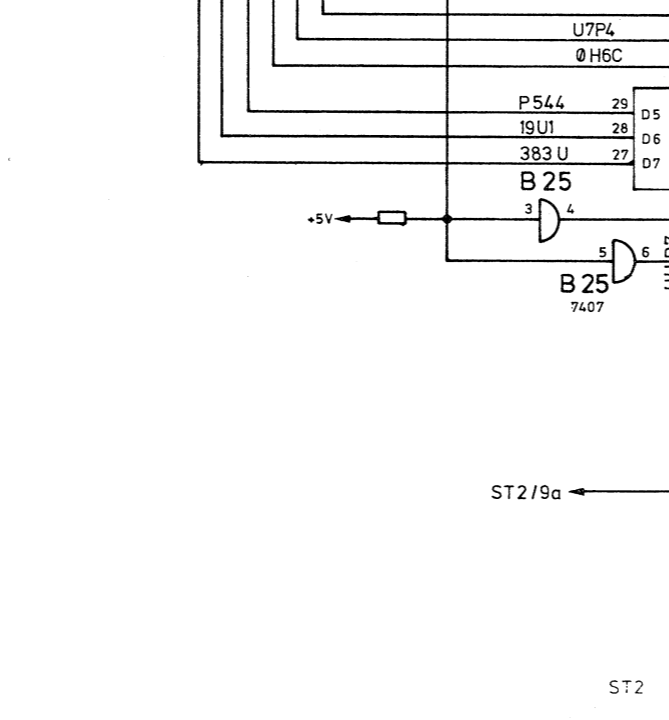
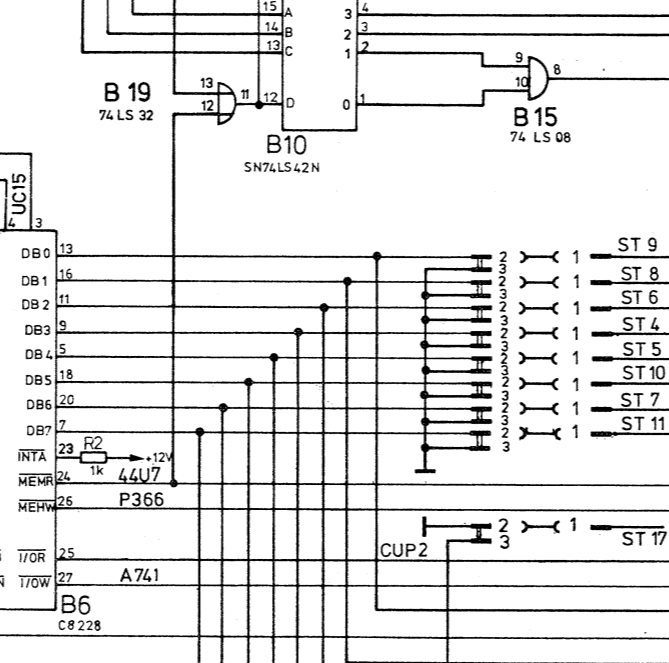
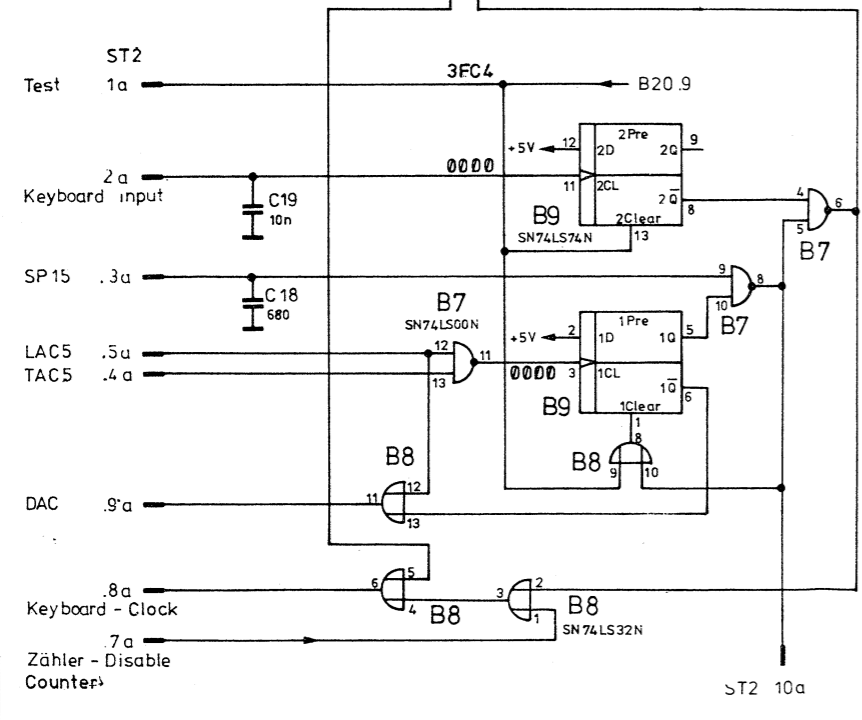
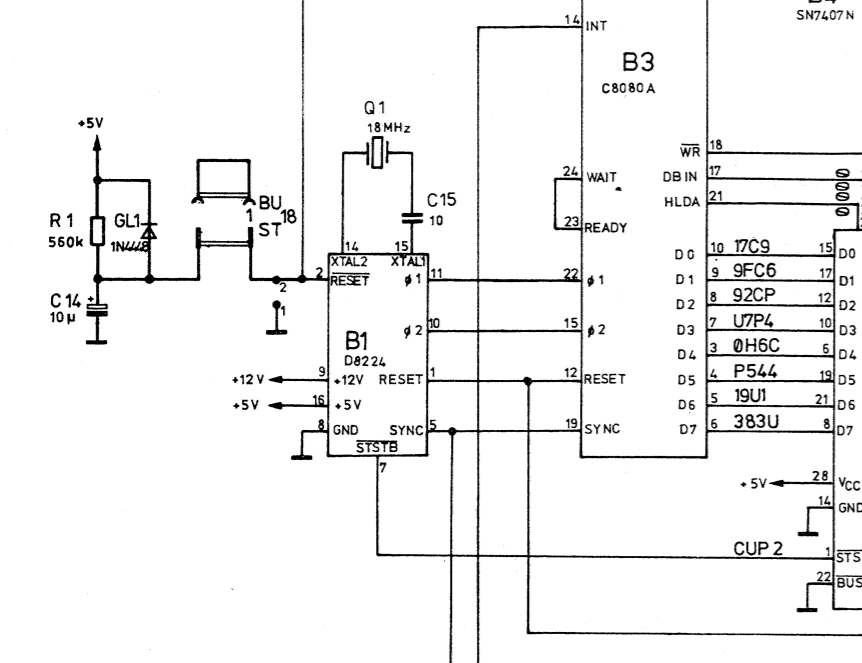
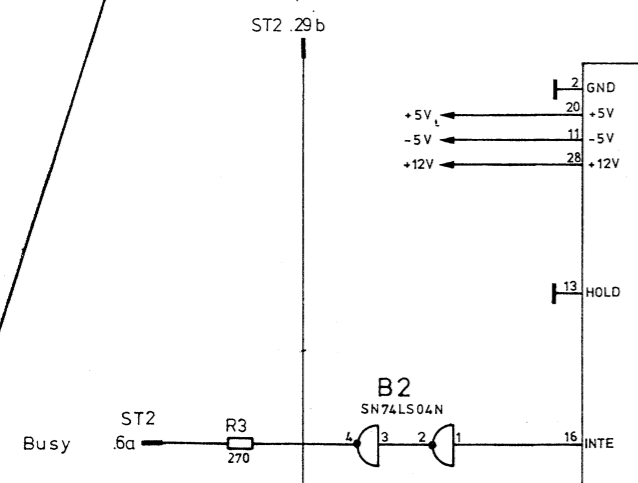
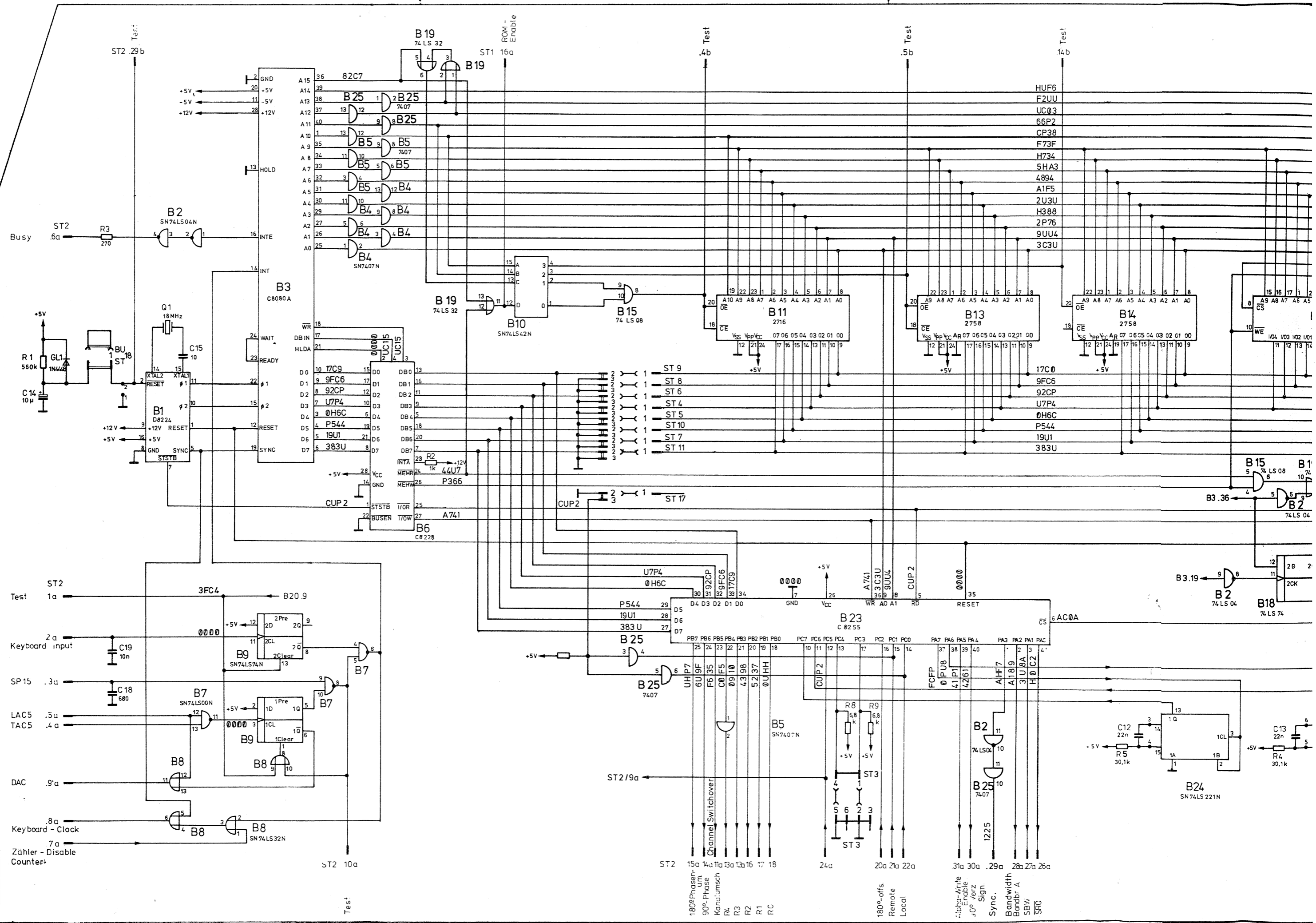
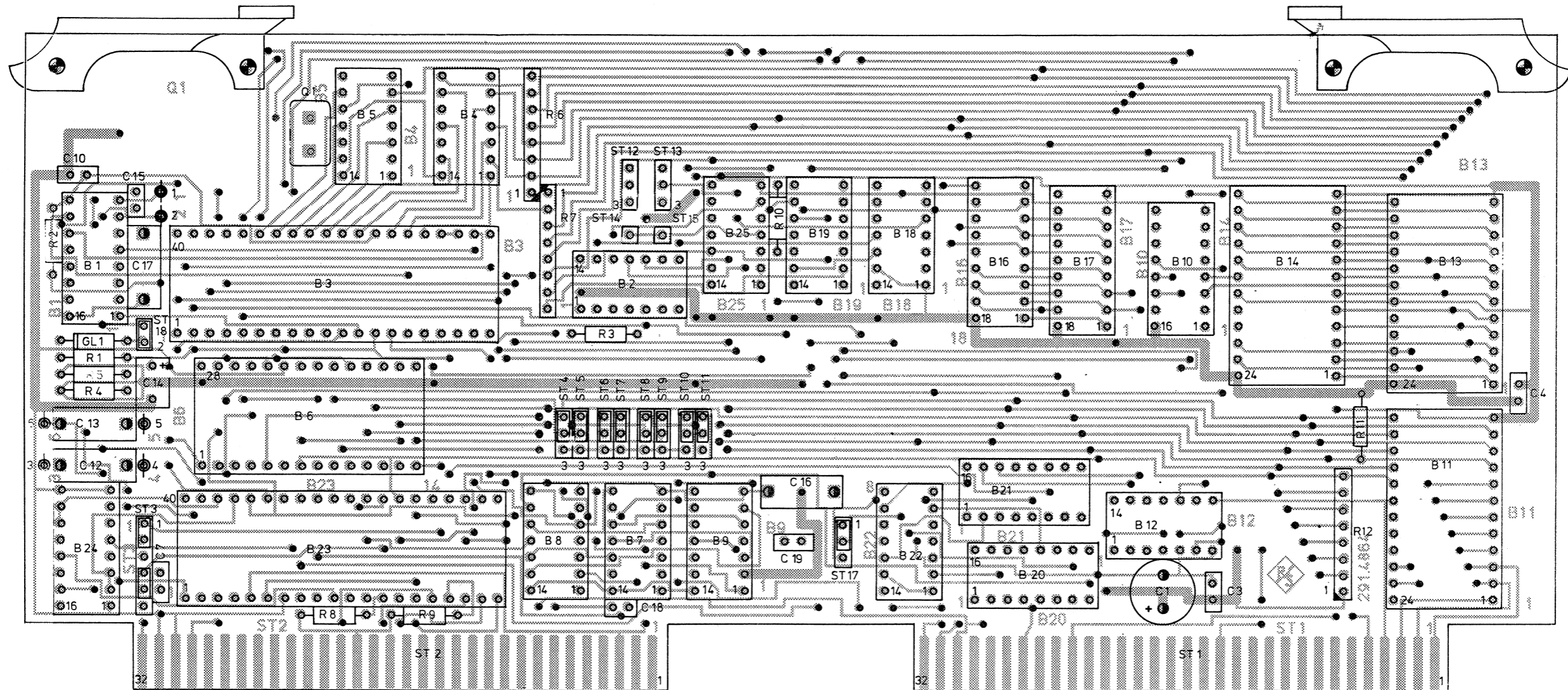

A		03.79	Li	Maße ohne Toleranzangabe		Maßstab		
B		25553	Li			Halbzeug Werkstatt		
				1GM	Tag	Name	Benennung	
				Beord.	2.11.78	NK	Rechnerplatte Computer board	
				Geor.				Z
				Norm				
				ROHDE & SCHWARZ MÜNCHEN		Zeichn.-Nr.		
						291.4864		
And. Zust.	Anderungs-Mitteilung	Tag	Name	zu Gerät ZPV		reg. 291.4012 V	erste Z 291.4012	

Ansicht und Leitungsführung Lötseite
View of tracks on solder side

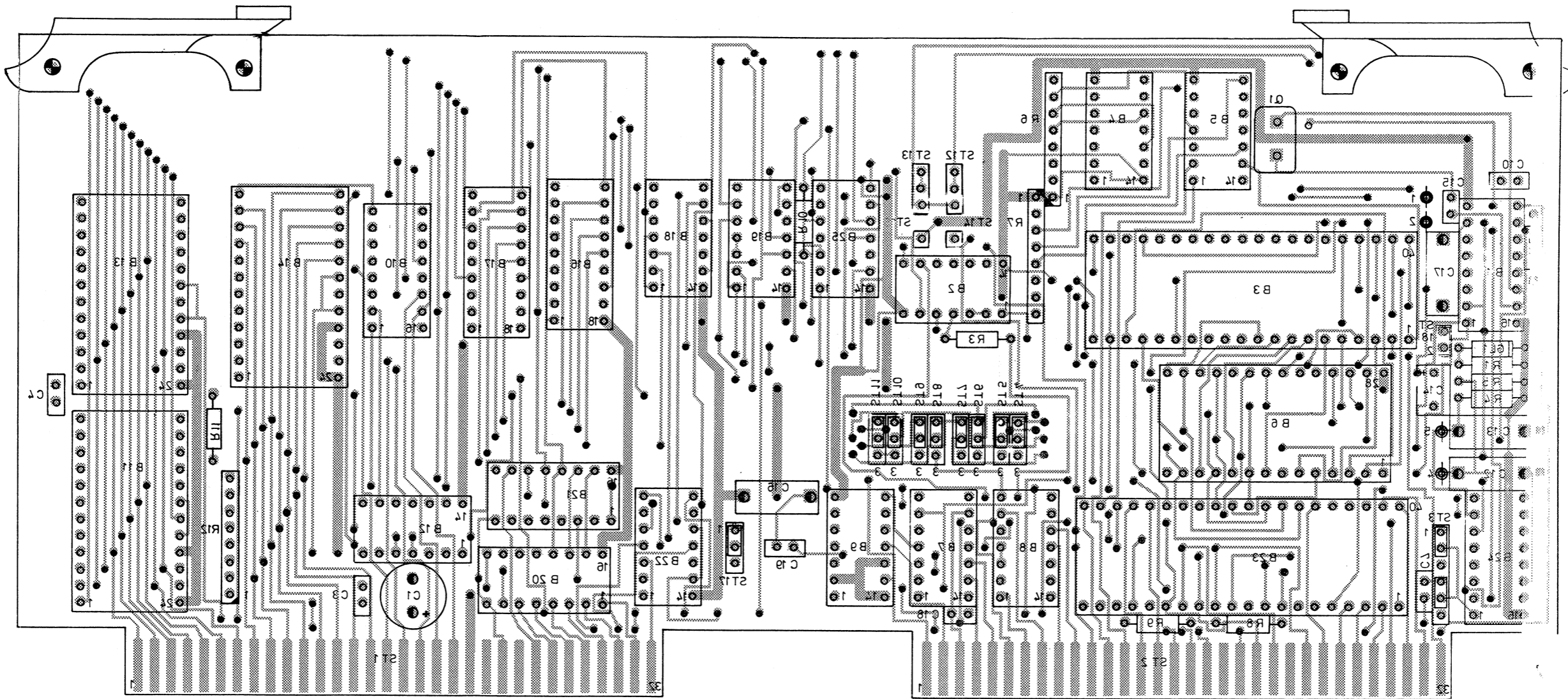

A		03.79	Li	Maße ohne Toleranzangabe		Maßstab	
B		25553	Li			Maßstab	
				1GM	Tag	Name	Benennung
				Bearb.	2.11.78	NK	Rechnerplatte Computer board
				Gepr.			
				Norm			
				ROHDE & SCHWARZ MÜNCHEN		Zeichn.-Nr.	
				Zu Gerät ZPV		291.4864	
And. Zust.	Änderungs-Mitteilung	Tag	Name	reg. 291.4012 V		erste Z. 291.4012	Bogen-Nr. 3